

M 165

Midrange specifications:

Name		HG-165M-3
DC resistance	R _{dc}	2,5 Ω
Nominal impedance	Z _N	3 Ω
Resonance frequency	f _s	59,1 HZ
Voice coil diameter		25 mm
Mechanical Q factor	Q _{ms}	3,94
Electrical Q factor	Q _{es}	0,92
Total Q factor	Q _{ts}	0,74
Moving mass	M _{ms}	14,07 g
Effective piston area	S _d	135 cm²
Mechanical resistance	R _{ms}	1,44Kg/s
Compliance	C _{ms}	0,52 mm/N
Force factor	BL	3,64 Tm
Equivalent air volume	V _{as}	10,96 dm³
Efficiency	η	0,24 %
SPL 2,83V/1m		90,74 dB

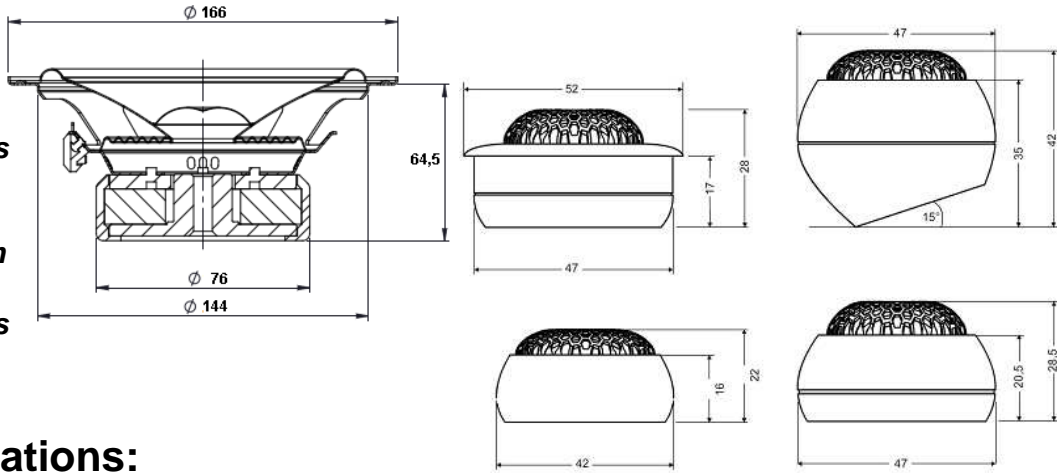
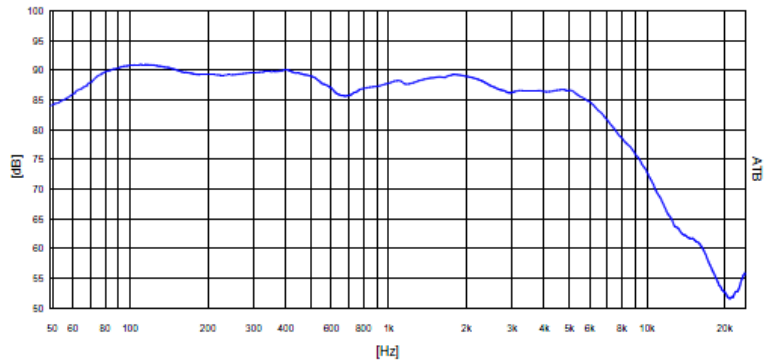

- Cone: **Fiberglass**
- Spider: **Nomex**
- Surround: **Rubber**
- Coil former: **Aluminum**
- Basket: **Steel**
- Dust cap: **Fiberglass**

Tweeter specifications:

Name		HG-25GF
DC resistance	R _{dc}	3,4 Ω
Nominal impedance	Z _N	4 Ω
Resonance frequency	f _s	1535 HZ
Voice coil diameter		25 mm

